

## Dry Pipe Systems Valve

## FIG. F2511-300 / F2512-300 / F2522-300

### Specifications

- Dry pipe system valve should be installed vertically orientation.
- For use in dry pipe (automatic sprinkler) fire protection systems.
- Multiple end type: Groove by Groove, Flange by Flange, Flange by Groove.
- Peroxide cured EPDM with fabric diaphragm. The valves and trim as specified by the Standard for the installation of sprinkler systems, ANSI/NFPA 13.
- Latched-Clapper type.
- Air supervisory pressure switches.
- Flanged connections are drilled per EN1092 -PN10/16 or ANSI B16.1 Class 125.
- Grooved connections are cut in accordance with standard groove specifications for steel pipe.

- UL 260 listed, GOST certificated.

### Working Pressure and Temperature

- 5 to 300 psi @ 0°C to 68°C.

### Corrosion Protection

- Fusion bonded coating interior and exterior meet or exceed all applicable of AWWA C550 standard.

### Options

- Multiple end type: Groove by Groove, Flange by Flange, Flange by Groove.
- Dry Accelerator.
- Water Motor Alarm.
- Alarm Pressure Switch.
- Drain Connection Kit.

### Material Specifications

Part	Material	ASTM Specification
Body	Ductile Iron	A536 Grade 65-45-12
Cover	Ductile Iron	A536 Grade 65-45-12
Body/Cover Gasket	Rubber	D2000 EPDM
Bonnet Bolts and Nuts	Carbon steel	A307 Grade B
Hange Pin	Stainless Steel	A276 Grade 304
Clapper	Bronze	B148 C95500
Clapper Seal	Rubber	D2000 EPDM
Seat Retainer	Stainless Steel	A276 Grade 304
Body Seat	Bronze	B62 C83600
Diaphragm	Rubber	Peroxide cured EPDM with fabric
Latch	Bronze	B148 C95500
Main Drain Valve	Bronze	B148 C95500
Dry Accelerator	Bronze	B148 C95500
Water Motor Gong	Assembly	
Nipple	Malleable Iron	A47 Grade 22010
Ball Valve	Brass	B16 C36000
Check Valve	Brass	B16 C36000
Low-Pressure Actuator	Bronze	B148 C95500
Strainer	Stainless Steel	A351 Grade CF8
Pressure Gauge	Assembly	
Spring	Stainless Steel	A276 Grade 302

### Notes

• Designs, materials and specifications shown are subject to change without notice due to the continuous development of our products.

### Schematic



## Dry Pipe Systems Valve

## FIG. F2511-300 / F2512-300 / F2522-300

### Main Dimensions

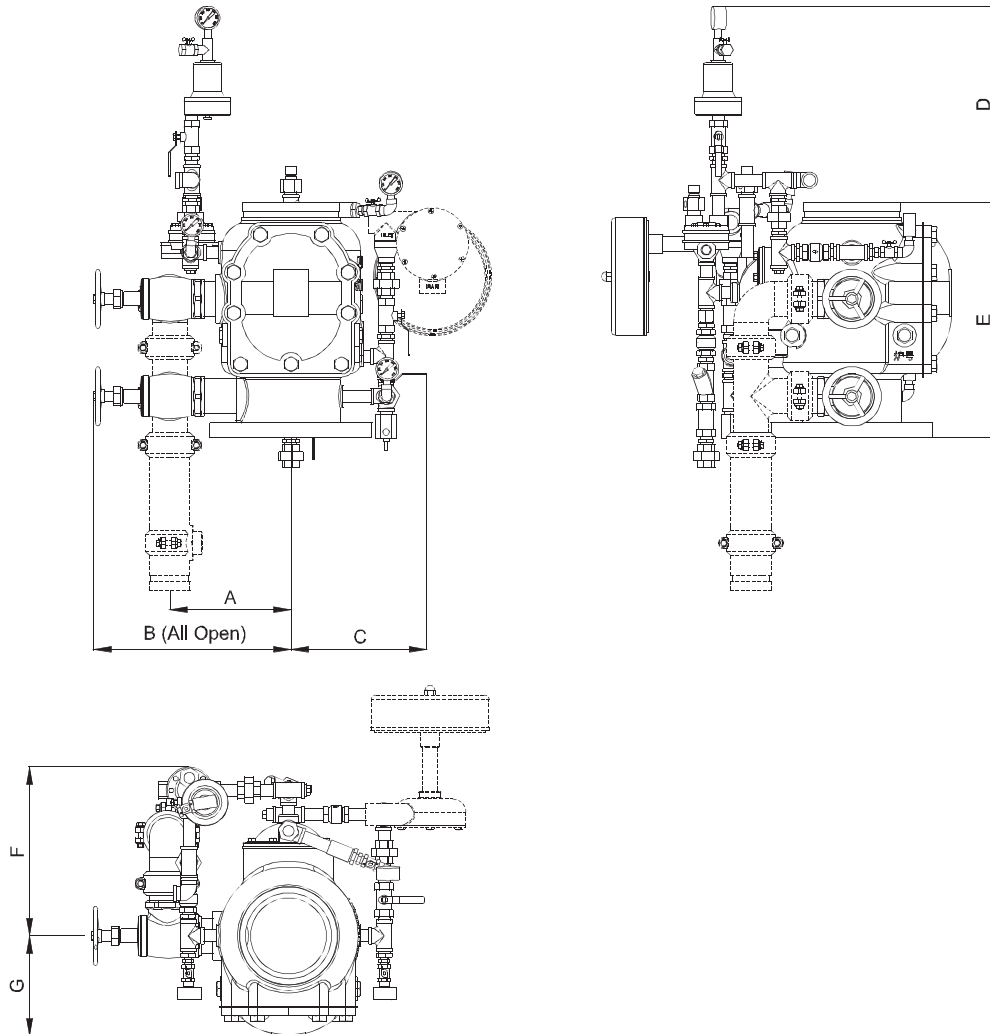

Size	A	B	C	D	E			F	G
					FXF	FXG	GXG		
3	150/5.90	300/11.81	210/8.27	375/14.76	325/12.80	310/12.20	310/12.20	265/10.43	120/4.72
4	180/7.09	350/13.78	210/8.27	375/14.76	355/13.98	343/13.50	343/13.50	265/10.43	135/5.31
6	210/8.27	375/14.76	250/9.84	345/13.58	431/16.97	405/15.94	405/15.94	290/11.42	175/6.89
8	240/9.45	415/16.34	275/10.83	325/12.80	460/18.11	445/17.52	445/17.52	310/12.20	190/7.48

#### Notes

• Designs, materials and specifications shown are subject to change without notice due to the continuous development of our products.